

'Superlock' Gate Lock

The 'SUPERLOCK' gate lock system has been designed and manufactured to the following criteria.

SECURITY – NON-CORROSIVE – ADAPTABLE – AESTHETIC – EASE OF INSTALLATION.

The advantages of 'SUPERLOCK' meets the demands of designers, architects, fabricators and clients alike.



**INSTALLS
IN
15
MINUTES**

'SUPERLOCK' IS RUSTPROOF

Because only non-ferrous metals such as aluminum, brass and stainless steel are used, 'SUPERLOCK' is rustproof, just as your treated gate, for at least 25 years. After surface treatment of your gate, the lock can be fixed very easily.

HIGH SECURITY 'SUPERLOCK'

To ensure that your gate is efficient, a high security lock is essential. 'SUPERLOCK' is just that: a robust, solid fixture and once the gate is closed the screws are inaccessible.

'SUPERLOCK' fits every profile, the bolts can be replaced in no time. In that way, different thicknesses of section can be used.

The lock has been designed to fit solid section, box section and tubular profiles. The latch is reversible.

The lock is supplied with a 54 mm euro profile cylinder and secured into position with concealed collars.

The lock is supplied with silver anodized or black wrought iron lever handles.

ALL DIMENSIONS ARE APPROXIMATE.

**WE CAN HELP YOU GROW YOUR BUSINESS.
CALL US TO BE ADDED TO OUR LIST OF FABRICATOR REFERRALS.**

All locks are supplied complete with cylinders, keys and lever handles. They are also available in either a black or aluminum finish.

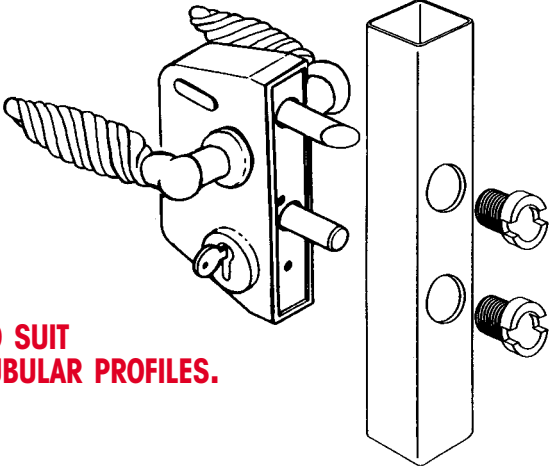

TO SUIT TUBULAR PROFILES.

94/13	to suit sections ranging from 1-1/4" to 2"	Black
94/14	to suit sections ranging from 1-1/2" to 2-3/8"	Black
94/15	to suit sections ranging from 2-3/8" to 3-1/4"	Black
94/16	to suit sections ranging from 1-1/4" to 2"	Aluminum
94/17	to suit sections ranging from 1-1/2" to 2-3/8"	Aluminum
94/18	to suit sections ranging from 2-3/8" to 3-1/4"	Aluminum

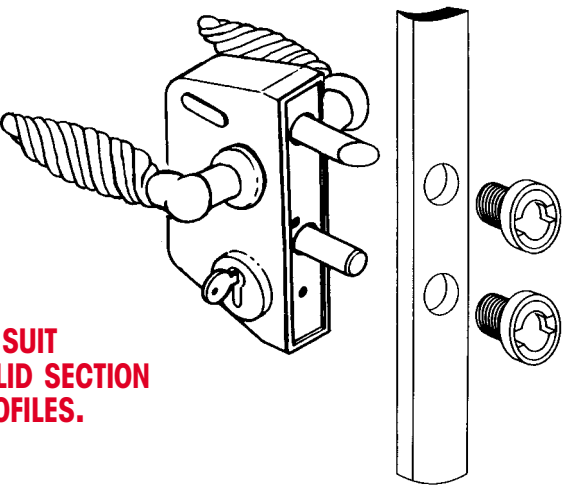

TO SUIT SOLID SECTION PROFILES.

94/19	to suit sections ranging from 3/8" to 1-1/4"	Black
94/20	to suit sections ranging from 3/4" to 1-1/2"	Black
94/21	to suit sections ranging from 3/8" to 1-1/4"	Aluminum
94/22	to suit sections ranging from 3/4" to 1-1/2"	Aluminum

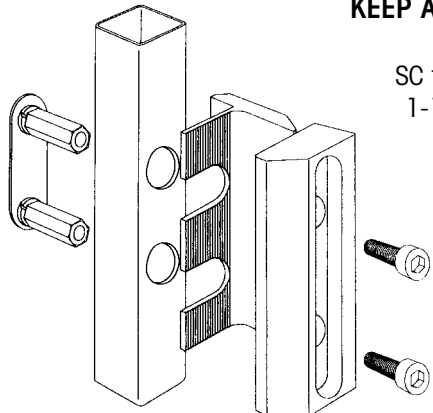

KEEP AND ADJUSTABLE STOP
SC to suit sections 1-1/2" to 3-1/4"

94/23



COLLAR SPANNER Required to bolt lock to gate.
Buy one with your first lock and keep for use with subsequent locks.

94/24

- 94/26** Spare cylinder – with 3 keys.
- 94/26K** Keyed alike cylinder – with 3 keys.
- 94/30** Blank key.
- JIG** Jig for drilling holes for installation. See page 115.

LOCK AND KEEP PLATES for tube section profiles 1-1/4" – 1-1/2" – 2" – 2-3/8"

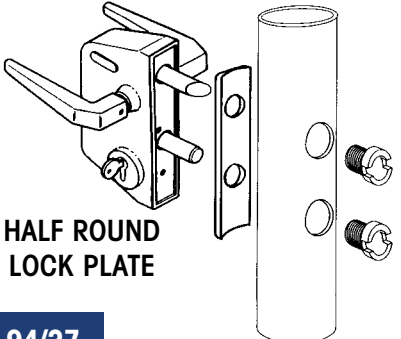

HALF ROUND LOCK PLATE

94/27

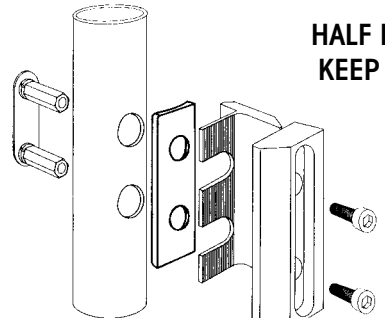

HALF ROUND KEEP PLATE

(shown with **94/23**)

94/28

SPARE FANCY ALUMINUM AND BLACK HANDLES



94/25A Aluminum
94/25 Black

ALL DIMENSIONS ARE APPROXIMATE.

"Superlock" - Latch and Bolt Adjustment

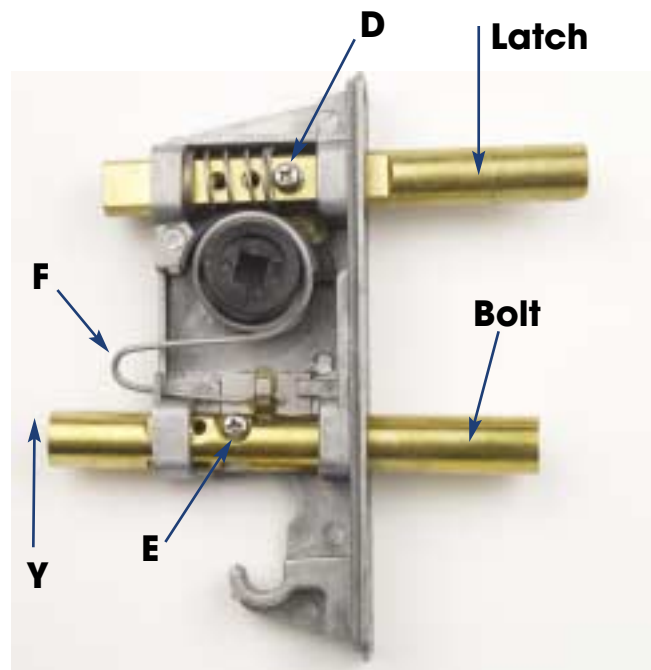
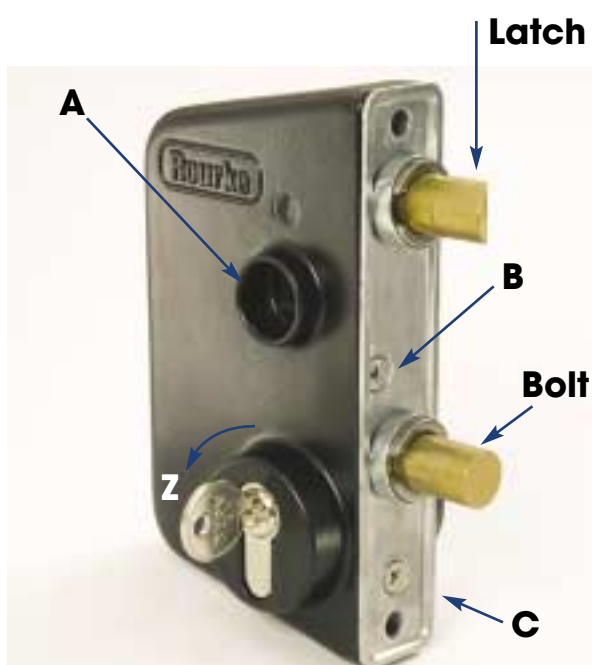

To separate outer case from chassis

1. Ensure both handles are removed from (A).
2. Undo Phillips head screw (B) and remove.
3. With key fully into lock (into barrel from side shown), turn key counterclockwise to approx. 11 o'clock.
4. Move key and lock barrel in direction (Z), and fully remove barrel.
5. Undo screw (C) and pull outer case from chassis face.

To adjust spring latch and bolt.

6. Undo screw (D) and position where required (or if catch needs to be other hand, rotate latch + the replace screw (D). Ensuring small steel lever (off plastic boss) and spring are not trapped by screw.
7. Push spring plate (E) up in direction (Y), slide bolt to required position. Release plate (E) and allow to drop into notch.
8. Replace chassis in case, ensuring spring (F) and black plastic boss are correctly positioned in chassis.

CAST STEEL PLATES TO COVER LOCKS.

Sold Individually

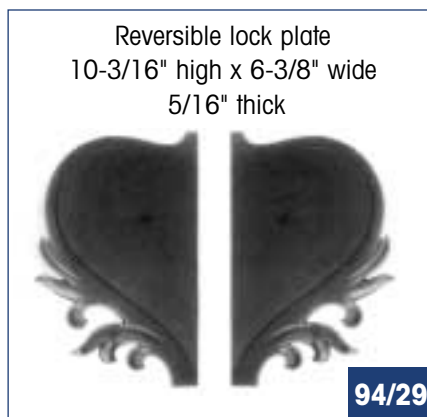
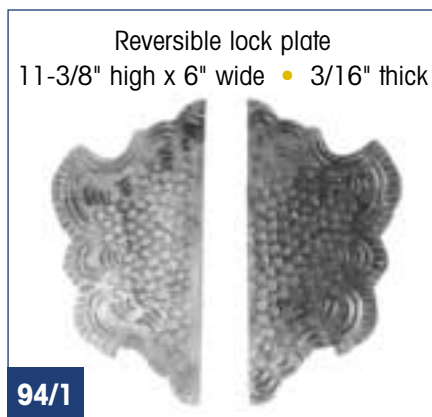

DRILL JIG



ALL DIMENSIONS ARE APPROXIMATE.

Architectural Iron Designs, Inc.

800.784.7444 • Fax: 908.757.3439 • www.archirondesign.com